



Monochrome Image Transmission over OFDM using Rate and Power Allocation

¹Divya R, ²Ramesh T M

¹PG student, M.Tech (Digital Electronics & Communication), ²Assistant Professor
Dept. of Electronics & Communication Engineering, The Oxford College of Engineering, Bangalore, Karnataka
Email: ¹divya.r.iyer90@gmail.com, ²rameshtmtoc@gmail.com

Abstract—Orthogonal Frequency Division Multiplexing (OFDM) is a method of encoding digital data on multiple carrier frequencies. We propose a modified OFDM system for robust progressive image transmission. This modified OFDM system employs Joint Source Channel Coder (JSCC). The Set Partitioning Hierarchical Trees (SPIHT) used as source coder and Low density Parity Check (LDPC) used as channel coder. The SPIHT coder is modified to produce four different groups of bit stream relative to its significances. An unequal error protection (UEP) is considered for data groups with the LDPC coder. Several PAPR reduction techniques like selective mapping (SLM), partial transmit sequence (PTS) and clipping have been proposed in this modified OFDM system. Comparing these techniques we prove that modified OFDM system along with JSCC and PTS technique will reduce PAPR and compensate resulting distortion and degradation in PSNR value.

Keywords— OFDM, PAPR, PSNR, SPIHT, LDPC, Unequal Error Protection (UEP), PTS, SLM.

I. INTRODUCTION

Image transmission over wireless communication requires robust and efficient source and channel coding algorithms. Hence we use SPIHT [1] algorithm which is the best image compressing method where original image can be reconstructed incrementally. A joint source channel coding [2] is found to be the best scheme for communication of images over noisy channels. SPIHT used for source coding of images to be transmitted. FEC scheme also employed to increase the transmitted data rate prior to transmission [3]. One of such FEC scheme is LDPC developed by Gallager [4].

Recent wireless multimedia applications desire high data rate. Earlier single carrier modulation techniques achieved limited data rate due to restrictions imposed by multipath effect of wireless channel and receiver complexity. As data rate in communication systems

increases, symbol duration gets reduced. Therefore communication systems using single carrier modulation suffer from severe intersymbol interference, thereby requires complex equalization mechanism.

Orthogonal Frequency Division multiplexing (OFDM) is one of the multi-carrier modulation (MCM) techniques for data-transmission by dividing a high-bit rate data stream into several parallel low bit-rate data streams and using these low bit-rate data streams to modulate several carriers [5][6][7]. Some advantages of OFDM are multipath delay spread tolerance, high spectral efficiency, immunity to frequency selective fading channels, effectiveness against channel distortion, throughput maximization. As a result OFDM is chosen for high data rate communication.

Peak to Average Power Ratio (PAPR) is one of the major problems with OFDM transmission, it exhibits a high peak-to-average ratio. The OFDM signal is basically a sum of N complex random variables, each of which considered as a complex modulated signal at different frequencies. In some cases, all the signal components add up in phase and produce a large output and in some, they may cancel each other producing zero output. Thus the peak-to-average ratio (PAR) of the OFDM system is very large.

The peak to average power ratio for a signal $x(t)$ is

$$\text{defined as } \text{PAPR} = \frac{\max_t |x(t)x^*(t)|}{E[x(t)x^*(t)]}$$

where $E[\cdot]$ denotes the expected value.

Expressing PAPR in decibels,

$$\text{PAPR}_{\text{dB}} = 10 \log_{10}(\text{PAPR})$$

The problem of PAPR is more serious in the transmitter. So to avoid clipping of the transmitted waveform, the power-amplifier at the transmitter frontend must have a

wide linear range to include the peaks in the transmitted waveform. Building power amplifiers with such large dynamic ranges is a costly affair. Further, this results in high power consumption.

There are some techniques by which PAPR can be reduced in OFDM systems such as clipping[7], companding [8][9][10], Partial Transmit Sequence (PTS)[11][12], Selective Mapping[13] and coding[14]. Simplest one is clipping the signal to a maximum allowed value, at the cost of BER degradation and out of band radiation.

The main aim of this paper is to improve the quality of the reconstructed image over OFDM system and reduce PAPR of the OFDM signal. Also compare various PAPR reduction techniques to show the significant reduction in PAPR. We propose a modified OFDM system with a JSCC scheme, which combines simple modification of SPIHT image coding technique followed by an UEP process using LDPC. The modified SPIHT coder generates four groups of bit streams. The significant bits, sign bits, set bits and refinement bits are transmitted in four different groups. The output of SPIHT image coding will be sent relative to its significant information. Also, Partial Transmit sequence technique is proposed for PAPR reduction for OFDM signal. The simulation results for the modified OFDM system and proposed PAPR reduction technique are obtained utilizing an image transmission over AWGN channel.

The rest of the paper is organized as follows. Section 2 presents the proposed modified OFDM system along with SPIHT and UEP process involving clipping, SLM and PTS as PAPR reduction techniques. Various PAPR reduction techniques that we have proposed here are explained in section 3. Section 4, introduces simulation results. Finally section 5 includes the conclusions followed by the relevant references.

SPIHT: The SPIHT algorithm has been introduced by A.Said and Pearlman. This algorithm is based on wavelet transformation which restricts the necessity of random access to the whole image to small sub images. Upon applying SPIHT, image quality will be improved with a high PSNR, fast coding and decoding and can also be used for lossless compression. This may be combined with error protection ability to code for exact bit rate or PSNR.

LDPC: LDPC codes are a class of linear block codes which provide a reliable transmission for coding performance that is very close to the Shannon's limit. A (n,k) LDPC code can be represented by a very sparse parity-check matrix having code rate $r=k/n$. It was originally invented by Gallager in 1963 and rediscovered by Mackay and Neal recently. LDPC has been adopted as the DVB-S2 standard.

II. PROPOSED MODIFIED OFDM SYSTEM BLOCK DIAGRAM

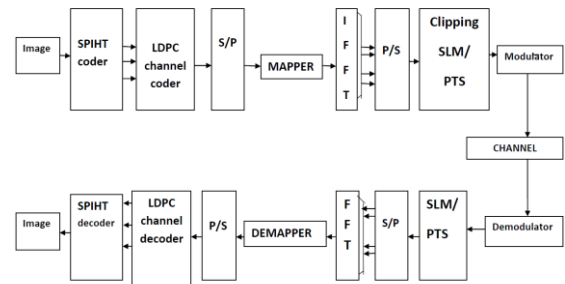

Fig 1: Modified OFDM system block

The block diagram of the proposed modified OFDM system is illustrated in figure 1.

The SPIHT coder is used as the source coding technique due to flexibility of code rate and simplicity. The SPIHT divides image bit stream into several groups according to its sensitivities and then the information bits are unequally encoded with the LDPC encoder.

The OFDM considered utilizes N frequency tones thereby the baseband data is first converted into parallel data of N sub channels so that each bit of a codeword is on different subcarrier. Then transmitted data of each parallel sub-channel is modulated by BPSK. Finally, the transmitted data are fed into an IFFT circuit, such that the OFDM is generated. At the receiver, the OFDM sub-channel demodulation is accomplished using a FFT then the parallel-to-serial(P/S) conversion is done. The received OFDM symbols will be demodulated at the demapper and decoded with the LDPC decoder and then data bits are restored and again converted into image format, such that SPIHT decoder will be obtained.

As shown in figure, the modified OFDM system includes PAPR reduction scheme for OFDM signals. Clipping the amplitude of input signals is one the simplest method for reducing PAPR.

III. PAPR REDUCTION TECHNIQUES

The proposed modified OFDM system includes non distortion techniques like Selected Mapping and Partial Transmit Sequence techniques for reducing PAPR.

A. Selective Mapping(SLM):

SLM is a technology in which multiple phase rotations are applied to constellation points, and the one that minimizes the time signal peak is used. It involves generating large set of data vectors all representing the same information. The data vector with lowest resulting PAPR is selected.

Here the actual transmit signals lowest PAPR is selected from a set of sufficiently different signals which all represents the same information.

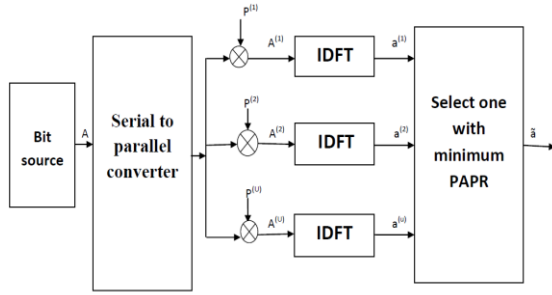

Fig 2: Basic block diagram for SLM technique

Consider a set of U distinct, pseudo-random but fixed vectors $\mathbf{P}^{(u)} = [P_0^{(u)}, \dots, P_{N-1}^{(u)}]$, with $P_n^{(u)} = e^{+j\vartheta_n^{(u)}}$, $\vartheta_n^{(u)} \in [0, 2\pi)$,

$0 \leq n \leq N$, $1 \leq u \leq U$. The subcarrier vector \mathbf{A} is multiplied subcarrier-wise with each one of the U vectors $\mathbf{P}^{(u)}$, resulting in $\mathbf{A}_n^{(u)} = \mathbf{A}_n \cdot P_n^{(u)}$, $0 \leq n \leq N$, $1 \leq u \leq U$. Then all U subcarrier vectors are transformed into time domain to get $\mathbf{a}^{(u)} = \text{IDFT}\{\mathbf{A}^{(u)}\}$ and finally that transmits a sequence with lowest PAPR is chosen.

B. Partial Transmit Sequence (PTS):

It is a non-distortion technique for PAPR reduction of OFDM signal. The fundamental idea behind partial transmit sequence technique is to divide the original OFDM symbol data into sub-data which is transmitted through the sub-blocks then multiplied by the weighing value which were differed by the phase rotation factor until choosing the optimum value which has low PAPR.

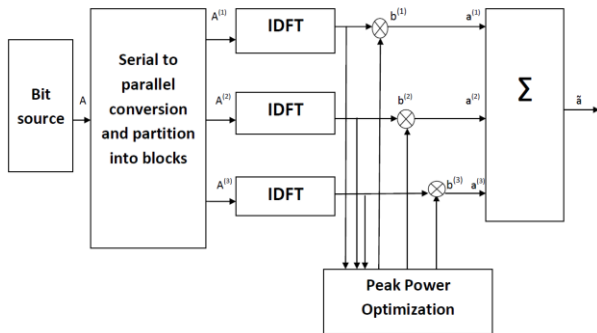

Fig 3: Block diagram for PTS technique

Figure 3 shows the block diagram for PTS technique. In this scheme, subcarrier \mathbf{A} is partitioned into M disjoint sub block $\mathbf{A}^{(m)}$, $1 \leq m \leq M$. All the subcarrier positions in $\mathbf{A}^{(m)}$ that are already represented in another sub block are set to zeros, so that

$$\mathbf{A} = \sum_{m=1}^M \mathbf{A}^{(m)}$$

We present complex valued rotation factors $b_{\mu}^{(m)} = e^{+j\varphi_{\mu}^{(m)}}$, $\varphi_{\mu}^{(m)} \in [0, 2\pi)$, $1 \leq m \leq M$ and μ is index of phase rotation of 'Peak power optimization', then modified subcarrier vector is

$$\mathbf{A}_{\mu} = \sum_{m=1}^M b_{\mu}^{(m)} \cdot \mathbf{A}^{(m)}$$

which represents same data as \mathbf{A} . Then to determine $\mathbf{a}_{\mu} = \text{IDFT}\{\mathbf{A}_{\mu}\}$, the linearity of the IDFT is utilized, sub blocks are then transformed by M separate parallel N -point IDFTs, resulting in

$$\mathbf{a}_{\mu} = \sum_{m=1}^M b_{\mu}^{(m)} \cdot \text{IDFT}\{\mathbf{A}^{(m)}\} = \sum_{m=1}^M b_{\mu}^{(m)} \cdot \mathbf{a}^{(m)}$$

Based on that a peak power optimization is performed by suitably choosing the free parameters $b_{\mu}^{(m)}$ such that the PAPR is minimized.

IV SIMULATION RESULTS

The above mentioned scheme is implemented using MATLAB. The modified OFDM system with proposed PTS technique was experimentally evaluated for 8bit (512 x 512) monochrome test image "LENA" over AWGN channel. The simulation parameters of OFDM system are $N=128$ subcarriers, code rate=1/2, CP=22 and transmission rate= 38.75bpp. The simulation results and the values for the maximum PAPR(PAPR_max) and Average PAPR(PAPR_avg) are shown in table.

Measure \ Scheme	PAPR_max	PAPR_avg
Mapping=BPSK SNR=5 dB		
Original OFDM	17.7959	11.0884
Modified OFDM	17.8217	7.4239
Modified OFDM with clipping	14.8093	6.2022
Modified OFDM with SLM 4	12.7180	13.3626
Modified OFDM with SLM 16	12.7180	12.7180
Modified OFDM with PTS 2	8.6218	6.2864
Modified OFDM with PTS 4	7.7550	5.9859

Table 1: Performance of the various PAPR techniques for PAPR reduction over AWGN channel

Figure 4 shows Complementary Cumulative Distribution Function(CCDF) comparison of PAPR for the modified OFDM system with and without clipping, SLM($U=4$ and $U=16$), PTS-2 and PTS-4 over AWGN channel with SNR=5dB and BPSK mapping.

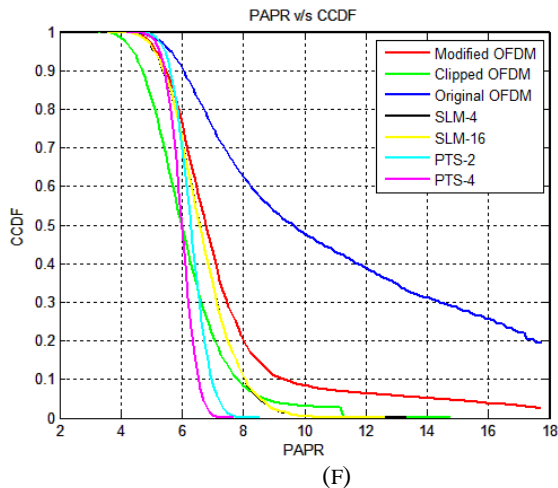

Fig 4: CCDF comparison of PAPR for the modified OFDM system with clipping, SLM and PTS over AWGN with BPSK

As shown from the simulation results we can say that PTS technique for PAPR reduction achieves good results and reduces the PAPR of the OFDM system.

V. CONCLUSION

In this paper, a modified OFDM system which employs a JSCC was proposed. This JSCC includes SPIHT as source coder and an LDPC as channel coder. Also PTS technique for PAPR reduction was proposed in the modified OFDM system. The performance of the modified OFDM was evaluated with transmitting the modified SPIHT image streams over AWGN channel. The simulation results show that modified OFDM system with PTS as PAPR reduction scheme provides significant improvement in PAPR in comparison to original OFDM. Moreover, the simulation results show that the proposed PTS technique outperforms the SLM and clipping method for PAPR reduction.

REFERENCES

- [1] A. Said and W. A. Pearlman, "A New Fast and Efficient Image Codec Based on Set Partitioning in Hierarchical Trees," *IEEE Trans. Circuit Syst. Video Technol.*, vol. 6, pp. 243-250, June 1996.
- [2] Junqing Liu, Dangui Xie, Shuifa Sun, "Progressive image transmission based on joint source channel distortion model", *International Conference on Computer Application and System Modeling (ICCASM 2010)*
- [3] S. Lin, and D. J. Costello, *Error Control Coding: Fundamental and Application*, Published by: Pearson Prentice Hall, 1983.
- [4] R. G. Gallager, "Low-Density Parity-Check Codes," *MIT Press, Cambridge*, 1963.
- [5] Y. Wu and W. Y. Zou, "Orthogonal frequency division multiplexing: A multi-carrier modulation scheme," *IEEE Trans. Consumer Electronics*, vol. 41, no. 3, pp. 392-399, Aug. 1995.
- [6] "Progressive Image Transmission over OFDM with Rate and Power Allocation," *IEEE 2013 Usama S. Mohammed, Osama A. Omer.*
- [7] W. Y. Zou and Y. Wu, "COFDM: An overview," *IEEE Trans. Broadcasting*, vol. 41, no. 1, pp. 1-8, Mar. 1995.
- [8] J. Kim and Y. Shin, "An Effective Clipped Companding Scheme for PAPR Reduction of OFDM Signals", *Proceedings of the IEEE ICC'08*, pp.668-672, 2008.
- [9] T. Jiang, W. Yao, P. Guo, Y. Song and D. Qu, "Two Novel Nonlinear Companding Schemes With Iterative Receiver to Reduce PAPR in Multi-Carrier Modulation Systems", *IEEE Transactions on Broadcasting*, Vol51, No. 2, pp. 268 - 273, Jun. 2006
- [10] F. S. AI-Kamali, M. I. Dessouky, B. M. Sallam, F. Shawki and F. E. Abd EI-Samie, "Performance Enhancement of SC-FDMA Systems Using a Companding Technique", *Ann. Telecommun.*, Vol. 65, No. 5-6, pp. 293-300, 2010.
- [11] L. Guan, T. Jiang, D. Qu and Y. Zhou, "Joint Channel Estimation and PTS to Reduce Peak-to-Average Power Ratio in OFDM Systems without Side Information", *IEEE Signal Processing Letters*, Vol. 17, No. 10, pp. 883-886, October 2010.
- [12] S. G. Kang, J. G. Kim, and E. K. Joo, "A novel subblock partition scheme for partial transmit sequence OFDM," *IEEE Trans. Commun.*, vol. 45, no. 9, pp. 333-338, Sep. 1999.
- [13] E. S. Hassan, S. E. EI-Khamy, M. I. Dessouky, S. A. EI-Dolil and F. E. Abd EI-Samie, "A Simple Selective Mapping Algorithm For The Peak To Average Power Ratio In Space Time Block Coded MIMO-OFDM Systems" *Proceedings of the International Conference on High Performance Computing, Networking and Communication Systems (HPCNCS-08)*, 2008.
- [14] T. Jiang and G. Zhu, "Complement Block Coding for Reduction in Peak-to-Average Power Ratio of OFDM Signals," *IEEE Communications Magazine*, vol. 43, no.9, pp. S17 - S22, Sept. 2005.

